

B. F. Bee.

Turning Lathe.

N^o 80,327.

Patented Jul. 28, 1868.

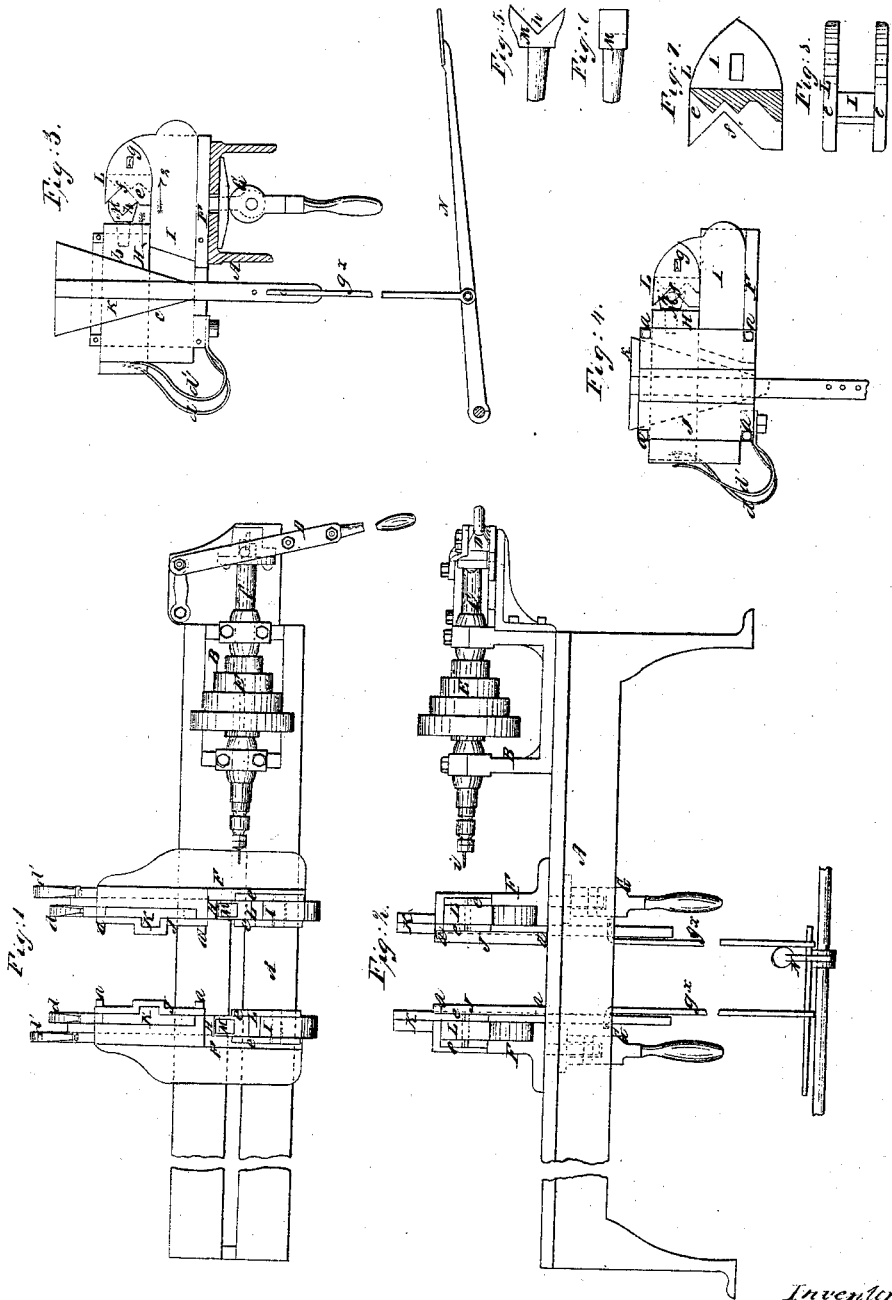

Witnesses:
Gustave D. ...
Am. W. Morgan

Inventor:
Bryan F. Bee,
per Munroe
Attorney

United States Patent Office.

BENJAMIN F. BEE, OF HARWICH, MASSACHUSETTS, ASSIGNOR TO THE NEW YORK TAP AND DIE COMPANY, OF NEW YORK CITY.

Letters Patent No. 80,327, dated July 23, 1868.

IMPROVEMENT IN CENTRING-LATHES.

The Schedule referred to in these Letters Patent and making part of the same.

TO ALL WHOM IT MAY CONCERN:

Be it known that I, BENJAMIN F. BEE, of Harwich, in the county of Barnstable, and State of Massachusetts, have invented a new and useful Improvement in Centring-Lathes; and I do hereby declare that the following is a full, clear, and exact description thereof, which will enable others skilled in the art to make and use the same, reference being had to the accompanying drawings, forming part of this specification, in which—

Figure 1 is a plan or top view of my invention.

Figure 2, a side view of the same.

Figure 3, a detached longitudinal vertical section of the centring-attachment.

Figure 4, a detached side view of the same.

Figure 5, a detached side view of one of the jaws of the same.

Figure 6, plan or top view of fig. 5.

Figure 7, a detached longitudinal vertical section of the jaw pertaining to the device.

Figure 8, a plan or top view of fig. 7.

Similar letters of reference indicate corresponding parts.

This invention relates to a new and improved centring-lathe, designed for centring articles, that is, adjusting their ends centrally in line with the bit of the lathe, so that the article may be drilled centrally or have centre-holes made properly in their ends, in order that they may be fitted centrally in a turning-lathe.

In the accompanying sheet of drawings—

A represents the bed of the lathe,

B the stationary or fixed head,

C the rotary sliding mandrel in the head B, the sliding movement being given to the mandrel by a lever D, and

E the cone of pulleys around which the band passes which gives the rotary motion to the mandrel.

These parts being old and well known, do not require a special description.

F represents a metallic bar, which is secured transversely on the bed A by a clamp, G, shown in fig. 3. This bar F is grooved at one side, so as to receive the slides H I, one, H, being placed above the other, I, and both allowed to move or work freely in a horizontal direction. These two slides are retained in proper position in the groove or recess in the bar F by means of a plate, J, secured to the side of F by screws a.

The slides H I are provided respectively with inclined shoulders, b c, between which a vertical v-shaped plate, K, is fitted, (see more particularly fig. 3,) and the rear ends of the slides are connected with springs, d d', which keep the shoulders b c in contact with the inclined sides of the plate K, the spring d, of the slide H, having a tendency to draw the latter in the direction indicated by arrow 1, and the spring d' of the other slide I, having a tendency to push the latter in the direction indicated by arrow 2, (see fig. 3.)

The lower slide I projects out considerably further than the upper slide H, and has a jaw, L, secured upon its upper surface at its outer end. This jaw is composed of two side-plates, e e, each of which has a v-shaped notch, f, made in its inner edge, the plates e e being secured by a pin or key, g, to the sides of I, which, at its outer end, projects upward a suitable distance to admit of the jaw L being in line with slide H, (see figs. 3 and 4.)

M is a jaw formed of a single plate, with a v shaped notch, h, made in its face-side, which notch corresponds in position or coincides with the notches f f in the plates e e of the jaw L. The jaw M is of such a width that it may pass between the plates e e of the jaw L when the two jaws are moved towards each other, (see fig. 4.)

The plate K has its sides inclined upward and outward, as shown clearly in figs. 3 and 4, and the lower end of said plate is connected by a rod, g', with a treadle, N, by pressing down which the two jaws L M are made to approach each other, and firmly grasp the article to be centred, and bring it in line with a drill, z, fitted in the mandrel C, the jaws L M having such a relative position with the bit as to effect this result. Owing to the notches in the jaws, they are made to grasp cylindrical and other-shaped articles, and properly present their ends to the bit.

In order to facilitate the centring of long articles, the centring-devices may be applied to the lathe of the bed, as shown in figs. 1 and 2, in order to steady and hold the article firmly in position while being operated upon.

Having thus described my invention, I claim as new, and desire to secure by Letters Patent—

The two slides H I, provided respectively with the jaws M L, in connection with the top plate K connected with the treadle N and the springs *d d'*, all arranged and applied to a centring-lathe to operate in the manner substantially as and for the purpose set forth.

BENJAMIN F. BEE.

Witnesses:

S. DAVIS KEENE,

F. T. SPENCER.